

Canon

Ultra-portable
Multimedia Projectors

LV-7355 / LV-7350

Project a 100-inch image from approx. 4 feet closer than previous models.

Big!



Wide

A remarkably short throw distance. And extra brightness in any situation. The LV-7355 and LV-7350 set a new standard in convenience for compact Native XGA projectors with these and many other features. Discover the Canon advantage.

Short Throw Distance

The projectors' ultra-wide zoom lens lets you project a 100-inch image from as close as 9.2 feet. They feature an unprecedented 1.5X motorized zoom, making them easy to set up in any size room.

Crisp XGA Resolution

Count on Native XGA resolution (1,024 x 768 pixels) to get all the details in your image that you need. You may also project SXGA resolution (1,280 x 1,024 pixels) through high-quality compression.

Enhanced Brightness

At the touch of a button, Canon's Turbo Bright System boosts brightness up to 2,200 ANSI lumens (LV-7355) or up to 1,800 ANSI lumens (LV-7350). This is done without increasing power consumption or sacrificing bulb life.

Advanced Connectivity

Each model comes equipped with a DVI-I interface for either digital or analog RGB input, allowing you to hook up two computers at the same time. They also feature component, S-Video, and RCA terminals, which allows you the freedom to connect to virtually any electronic device.

www.canonprojectors.com



LV-7355/LV-7350

Nomenclature

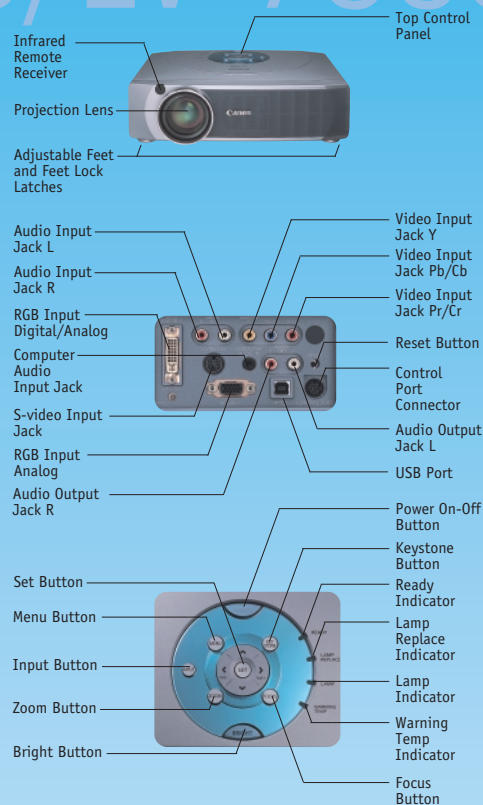

Specifications

Type: Ultra-portable LCD Projector
LCD Panel: 0.9" polysilicon active matrix TFT x 3. 4:3 aspect ratio
Number of Pixels: 786,432 1,024(H) x 768(V)
Supported Display Standards: Native XGA, SXGA (Compression), SVGA, VGA
Light Source: 200W UHP lamp
Brightness (Brighter mode/True Color mode): LV-7355: 2,200/1,900 ANSI lumens, LV-7350: 1,800/1,500 ANSI lumens
Uniformity: 85%
Contrast Ratio: 350:1 (All white/All black)
Horizontal Resolution: 800 TV lines
Projection Lens: 25.7 to 37.9 mm, F1.7 to 2.44, 1.5X zoom
Lens Shifting: 9:1
Elevation Adjustment: Up by 15.6° (One-touch adjustment)
Projected Image Size (Projection Distance): **WIDE mode:** 45" (3.9 ft.), 100" (9.2 ft.), 150" (13.8 ft.), 200" (18.4 ft.), 300" (28.2 ft.) **TELE mode:** 30" (3.9 ft.), 68" (9.2 ft.), 100" (13.8 ft.), 134" (18.4 ft.), 200" (28.2 ft.)
Digital Keystone Distortion Compensation Angle: ±20° (vertical), ±10° (horizontal)
Color System: NTSC/PAL/SECAM/NTSC 4.43/PAL-M/PAL-N
Supported Computers: IBM PC compatible, Macintosh, PC98, workstation (Some workstations are not supported.)
Scanning Frequency: 15 to 100kHz for horizontal sync., 50 to 100Hz for vertical sync., 140MHz for dot clock
Audio Output: 1W monaural
Built-in Speaker: 1.6 x 1.2 in., x1
Rated Supply Voltage: 100 to 120/200 to 240V AC, 50/60Hz
Power Consumption: 300W
Ambient Operation Temperature: 41 to 95°F (5 to 35°C)
Storage Temperature: 14 to 140°F (-10 to 60°C)
Dimensions (W x H x D): 13.1 x 3.5 x 9.6 in./331.5 x 89.5 x 244.1 mm excluding legs. (Legs: 0.5 in./11.5 mm)
Weight of Main Unit: Approx. 9.46 lbs. (4.3kg)

All specifications are subject to change without notice. Canon is a registered trademark of Canon, Inc.

Ideal for Corporate Offices, SOHOs, and Home Theaters!

Superior Optical Technology

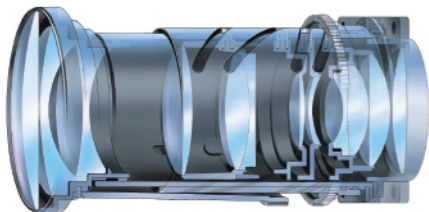

Featuring an innovative Canon-developed lens, the LV-7355 and LV-7350 are the first multimedia projectors to offer 1.5X motorized zoom. This expands your range of throw distances, giving you flexibility with projector placement. And because the lens is wide, you don't need as much room for large-size projection—100-inch images, for example, can be projected from almost 4 feet closer than previous models. Canon's renowned lens expertise ensures low distortion and enhanced color fidelity as well.

Diverse Options

When you want to go wireless, use the Wireless Imager* to transfer data from your laptop to the projector. Or, for presentations without a PC, the Media Card Imager is available.

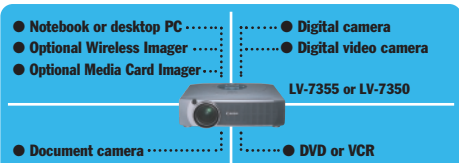

* When using this device, switching to the next image and mouse response may be slower compared to a RGB cable connection.

Flexible Image Adjustment

Use gamma adjustment to change picture quality as you like, and save this customized setting for later use. A total of 12 settings are included to ensure the best quality in all situations.

Distortion-free Images

The LV-7355 and LV-7350 feature Horizontal and Vertical Keystone Correction to keep your images perfectly proportioned.

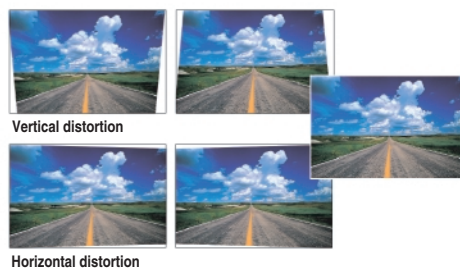

User-friendly Operation

Automatic adjustment kicks in the moment you plug in your video or data source, and you'll enjoy quiet operation from start to finish. A handy remote control provides easy access to digital zoom, image freeze, and other key functions.

LV-7355/7350 Kit Contents:

Projector • Wireless remote control (AA alkaline batteries included) • VGA computer cable • DVI/VGA adapter • Mouse control cable for PS/2 • Lens cap • Soft carrying case • Power cable • Warranty card • User's manual

Available Options:

Wireless Imager • Media Card Imager

Canon KNOW HOW™

Canon U.S.A., Inc.
 One Canon Plaza
 Lake Success, NY 11042, U.S.A.

Canon Canada Inc.
 6390 Dixie Road
 Mississauga,
 Ontario L5T 1P7, Canada

Canon Mexicana, S. DE R.L. DE C.V.
 Periférico Sur No. 4124, 5º y 6º pisos,
 Col. Ex-Rancho de Anzaldo,
 01900 México, D.F.

Canon Latin America
 703 Waterford Way Suite 400
 Miami, FL 33126, U.S.A.

1-800-OK-CANON www.canonprojectors.com